

SD 12x SERIES SENSORS – INTELLIGENT TEMPERATURE SENSORS WITH A STEM AND PLASTIC ENCLOSURE



DESCRIPTION AND APPLICATION

The sensors of the serie SD 12x are intelligent microprocessor-controlled temperature sensors. These sensors are intended for contact temperature measurements of liquid or gaseous substances. The sensor-central holder combination is suitable for temperature measurements in air condition ducts. The sensor-thermowell combination is suitable for temperature measurements in tubing. The standard temperature range in which the sensors are allowed to be utilised is -40 to 150 °C. The sensors communicate by means of RS 485 bus and only the bus can control the sensors. Communication inputs are protected to overvoltage. In case the module is placed as terminal on the line, a terminating resistor can be attached to the wiring by shorting the contacts (the switch SW placed next to terminals for communication lines connection). All settings are stored in EEPROM memory. The electronic module is equipped with the WATCHDOG circuit, which safeguards proper program functioning in the microprocessor. Easy mounting of the temperature sensor is ensured by the unique "S head" design.

The sensors are designed to be operated in a chemically non-aggressive environment. The sensors are made in three basic variants:

- SD 120** – with a simple ASCII communication protocol corresponds with ADAM 4000 modules by ADVANTECH company. Thus, standard drivers for ADAM modules can be used in various control programmes. For easier operation, the green LED indicates if power supply is on and the red LED indicates that the module is communicating. the SD 1x0 module is provided by the INIT shorting jumper on its printed circuit board. If it is shorted when power is switched on, the module communicates on 00 address with 9600 Bd transfer speed without checksum.
- SD 121** – the command structure corresponds with the ARION communication protocol, which is used among control systems by Amit company.
- SD 122** – the command structure corresponds with the ModBus communication protocol.

ACCESSORIES

- The central plastic holder
- The thermowell JS 130
- The metal central holder

DECLARATION, CERTIFICATES, CALIBRATION

EC Declaration of Conformity – in accordance with Act No. 22/1997 Coll. as amended for sensors with an digital output.

Calibration – we perform standard calibration of resistance temperature sensors in accordance with EN ISO/IEC 17025 standard in the temperature range of the stated type of sensor.

SPECIFICATIONS

Sensor type	SD 120	SD 121	SD 122
Power supply	10 to 35 V DC (unstabilized) 14 to 24 V AC		
Power consumption	max. 1000 mW		
Measuring range	-40 to 150 °C		
Standard stem lengths	70, 120, 180, 240 mm		
Communication properties	communication via RS 485, maximum segment length is 1200 m, asynchronous transfer		
	transfer speeds 1200, 2400, 4800, 9600, 19200 Bd	transfer speeds 9600, 19200, 38400, 57600 Bd – DIP switch	preset transfer speed 9600 Bd optional transfer speeds 1200, 2400, 4800, 19200, 57600, 115200 Bd - DIP switch
	256 modules / 1 serial port	63 modules / 1 serial port	247 modules / 1 serial port
	protocol consistent with ADAM modules	protocol ARION	protocol ModBus 1 stop bit, without parity
Accuracy of electronics	0.05 %		
Accuracy of sensing element	± 0.5 °C		
Resolution	0.01 °C		
Ingress protection	IP 65 according to EN 60 529		
Material of the sensor stem	stainless steel 1.4301		
Material of the enclosure	POLYAMID		
Working conditions	ambient temperature: -30 to 70 °C		
	relative humidity: max. 85 % (at the ambient temperature 25 °C) atmospheric pressure: 87 to 107 kPa		
Weight	0.2 kg		



WIRING DIAGRAM

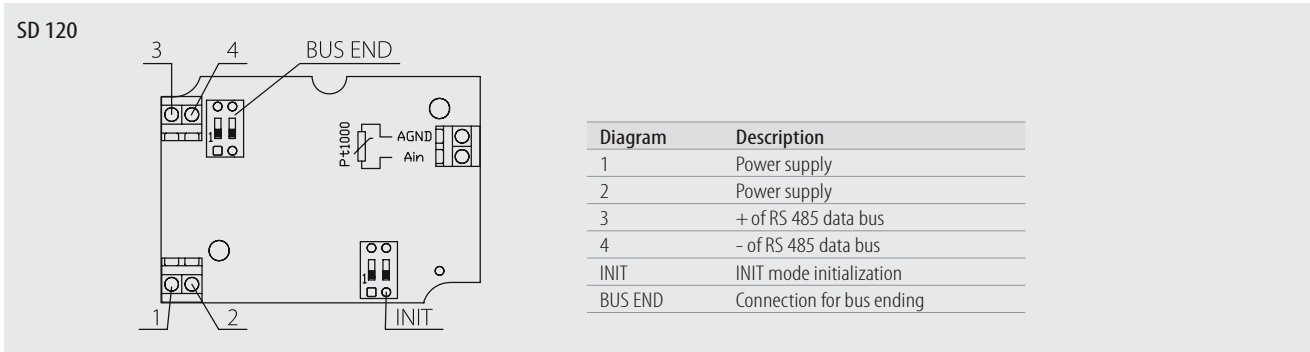

DIMENSIONAL DRAFT

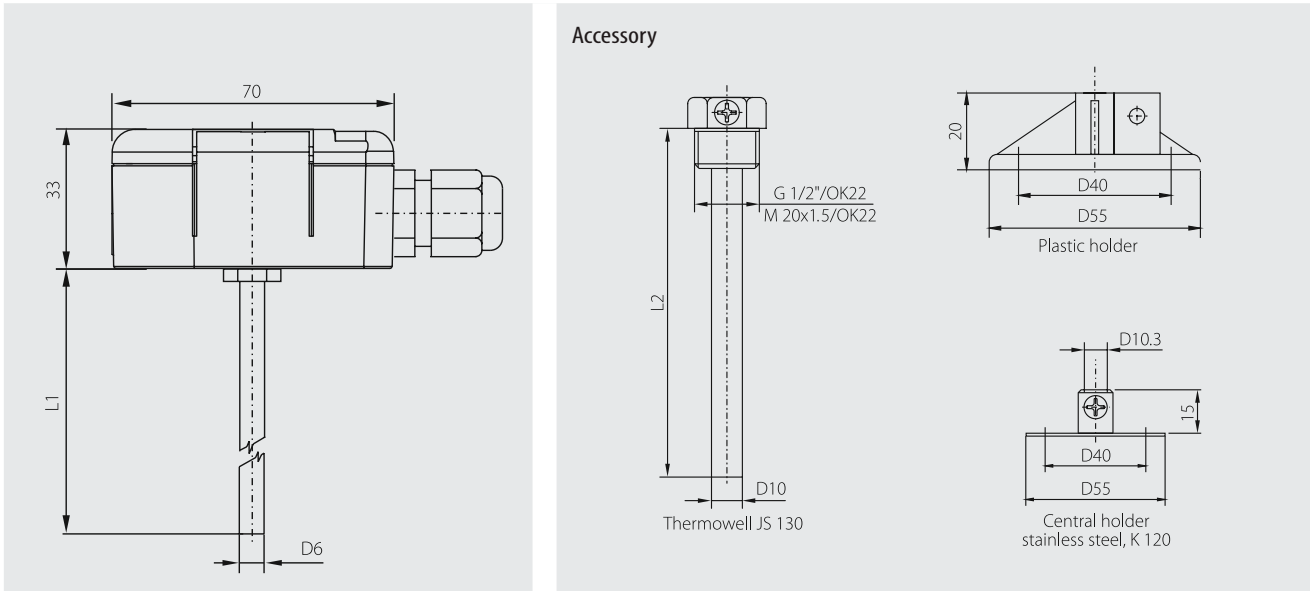

SENSOR INSTALLATION AND MAINTENANCE

Before connecting the supply lead-in cable, lift off the lid of the plastic enclosure by means of a flat screwdriver. The lead-in cable is connected to the terminals according to the wiring diagram through the loosened grommet. The recommended wire cross section is 0.35 to 1.5 mm², the outer diameter of the circular cross-section cable can range between 4 and 8 mm. To ensure the ingress protection value of IP 65, the grommet has to be tightened and the lid has to be put on after connecting the lead-in cable.

In case the lead-in cable is laid in the vicinity of high voltage conductors or those supplying equipment creating disturbing electromagnetic field (e.g. inductive load equipment), a shielded cable should be used. In case of using a stainless steel thermowell or a stainless steel holder these accessories should be placed first in the location where the temperature will be measured. Then the sensor is inserted into the holder, or pushed as far as the thermowell bottom, and tightened with a screw. The openings for the plastic clip installation have to be drilled according to the dimensioned sketch on which the opening diameters and the distances of their centres are illustrated. After installing and connecting the sensor to the sequential evaluating electrical equipment the sensor is ready to use. The sensor does not require any special servicing or maintenance. The device can be operated in any working position, but the grommet must not be directed upwards.

CUSTOMER SPECIFIC MODIFICATIONS

REGARDING TO SENSORS MANUFACTURED IN A STANDARD VERSION THE FOLLOWING PARAMETERS CAN BE MODIFIED:

- variable stem design – L1 length, materials, diameters, option of thread design
- thermowell thread type options