

TEMPERATURE SENSORS (IP 68) UP TO 600 °C

**DESCRIPTION AND APPLICATION**

These resistance-type sensors are intended for contact measurements of temperatures up to 600 °C. Temperature sensors, in combination with a central holder or thermowell, can be used to measure the temperature in various applications of an industrial environment. The sensor variant with welded thread is ideal for direct measuring of various media in ducts. **These sensors meet the IP 68 rating** in accordance with EN 60 529. The standard operating temperature range is -50 to 600 °C. The sensors can be utilised for control systems that are compatible with sensing element output signals or output signals quoted in the table of sensing element types. The sensors are designed to be operated in a chemically non-aggressive environment.

**ACCESSORIES**

- The metal central holder K 120
- The thermowell JPTS 41

**DECLARATION, CERTIFICATES, CALIBRATION**

**Declaration of Conformity** – in accordance with EN ISO/IEC 17050-1 standard as amended for sensors with resistance output.

**EC Declaration of Conformity** – in accordance with Act No. 22/1997 Coll. as amended for sensors with an output of 4 to 20 mA.

**Calibration** – we perform standard calibration of resistance temperature sensors in accordance with EN ISO/IEC 17025 standard in the temperature range of the stated type of sensor.



**MAXIMUM STREAM VELOCITY OF THE MEASURED MEDIUM - AIR AND WATER VAPOUR / WATER [m.s<sup>-1</sup>]**

Length of the thermowell/stem	> 60 to 100 mm	> 100 to 160 mm	> 160 to 220 mm	> 220 to 400 mm
Values for the versions with screw joint	15 / 1.5	8.0 / 1.0	2.5 / 0.6	0.6 / 0.3

**SPECIFICATIONS**

**BASIC DATA**

Sensor type with smooth stem	PTS 641	PTS 645
Sensor type with welded-on screwed joint	PTS 661	PTS 665
Type of sensing element	Pt 100	Pt 1000
Measuring range B class	-50 to 600 °C, on a short term to 650 °C	
Maximum measuring DC current	3 mA	1 mA

Sensor type with smooth stem	PTS 651	Note
Sensor type with welded-on screwed joint	PTS 671	
Type of sensing element	Pt 1000/3850	Connection head ambient temperature -30 to 80 °C
Output signal	4 to 20 mA	
Measuring ranges	-50 to 50 °C	
	0 to 100 °C	
	0 to 150 °C	
	0 to 200 °C	
	0 to 400 °C	
Power supply (V <sub>CC</sub> )	11 to 30 V DC	Recommended value 24 V DC
Maximum voltage ripple V <sub>CC</sub>	0.5 %	
Load resistance	50(V <sub>CC</sub> -10) Ω	
Output signal - sensing element break	> 25 mA	
Output signal - sensing element short	< 3.5 mA	

**OTHER PARAMETERS**

Accuracy class	B class according to IEC 751, Δt = ± (0.3 + 0.005 t ) in °C
Measuring error (PTS 651, PTS 671)	< 0.6 % of the measuring range, minimum 0.5 °C
Sensor connection	4-wire
Standard length of the stem L1	50, 100, 160, 220, 280, 400 mm
Nominal pressure of the stem	PN 63 (with a screw joint)
Response time	τ <sub>0.5</sub> < 9 s (in streaming water at 0.4 m.s <sup>-1</sup> )

TEMPERATURE SENSORS (IP 68) UP TO 600 °C

Recommended wire cross section	0.35 to 1.5 mm <sup>2</sup>
Thead types for PTS 661, PTS 665, PTS 671	G 1/2"; M 20 x 1.5; M 27 x 2
Insulation resistance	> 200 MΩ at 500 V DC, 25° ± 3 °C; humidity < 85 %
Ingress protection	IP 68 according to EN 60 529, 5 bar/30 min.
Material of the stem	stainless steel EN X6CrNiTi 18-10 (DIN 1.4541)
Material of the connection head	aluminium LIMATHERM B
Grommet type	M 20 x 1.5
Operating conditions	ambient temperature: -30 to 100 °C; -30 to 80 °C with a converter
	relative humidity: max. 85 % (at the ambient temperature 25 °C)
	atmospheric pressure: 87 to 107 kPa
Weight	approximately 0.25 kg

**WIRING DIAGRAM**

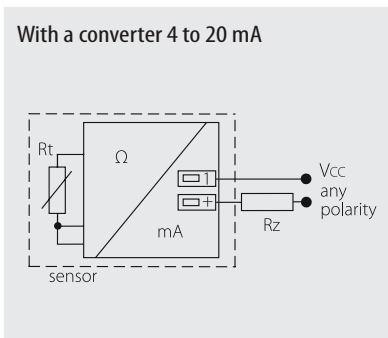
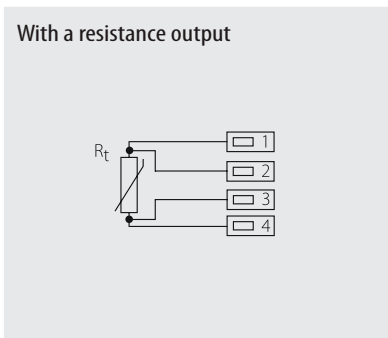

**DIMENSIONAL DRAFT**

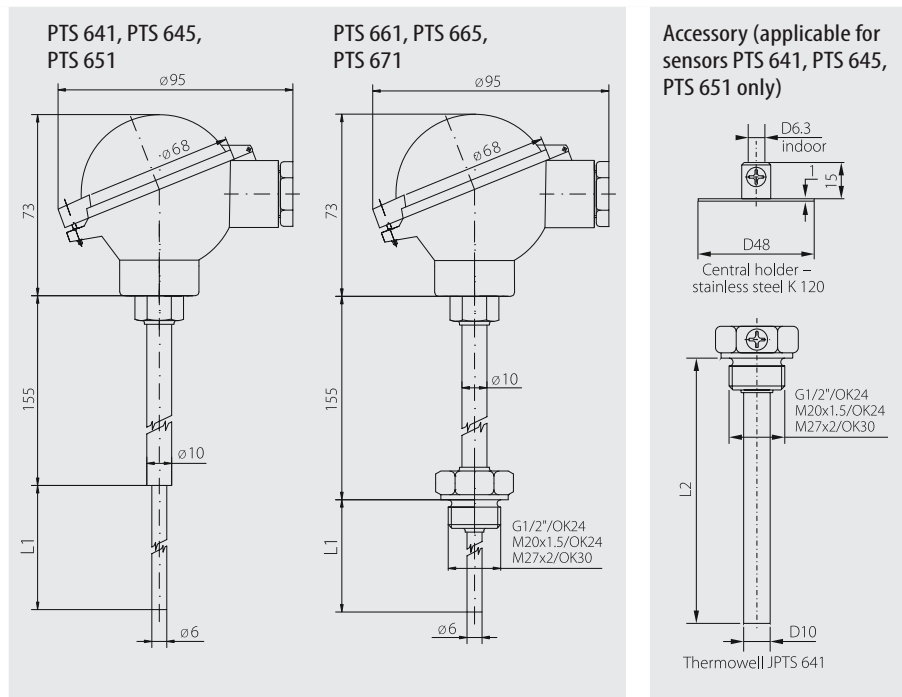

**SENSOR INSTALLATION AND SERVICING**

Before connecting the supply lead-in cable, position the sensor in the location of temperature measurement, and screw off the lid of the metal connection head. The lead-in cable is connected to the terminals according to the wiring diagram after pushing it in through the loosened grommet. The recommended wire cross section is 0.35 to 1.5 mm<sup>2</sup>, the outer diameter of the circular cross-section cable can range between 4 and 8 mm. In case the lead-in cable is laid in the vicinity of high voltage conductors or those supplying equipment creating disturbing electromagnetic field (e.g. inductive load equipment), a shielded cable should be used. To ensure the ingress protection value of IP 68 the grommet has to be tightened and the lid has to be screwed on after connecting the lead-in cable.

In case of using a stainless steel thermowell or a holder these accessories have first to be installed in the temperature measurement location, then then the sensor shall be pushed into the holder or eventually to the thermowell bottom, after which the sensor is secured with a screw. (This applies for the PTS 641, PTS 645 and PTS 651 sensors only). The openings for the stainless steel holder installation have to be drilled according to the attached template, on which the opening diameters are illustrated, too. (This applies for the PTS 641, PTS 645 and PTS 651 sensors only). After installing and connecting to the appropriate evaluating electrical equipment the sensor is ready to use. The sensor does not require any special service or maintenance. The device can be operated in any working position, but the grommet must not be directed upwards.

**CUSTOMER SPECIFIC MODIFICATIONS**

REGARDING TO SENSORS MANUFACTURED IN A STANDARD VERSION THE FOLLOWING PARAMETERS CAN BE MODIFIED:

- option enclosing two sensors
- A class of accuracy for the range -50 to 200 °C
- option of three- or four-wire connection
- variable stem design – L1 length, materials, diameters, option of thread design
- thermowell thread type options